

Ultra-low power multi-gas sensor for monitoring indoor air quality

Cambridge CMOS Sensors Technology Advantage

Our patented CMOS MEMS Micro-hotplate technology provides a unique silicon platform for our Metal Oxide (MOX) gas sensors and enables sensor miniaturisation, significantly lower power consumption and fast heating times.

Our resistive Micro-hotplates are fabricated using a high reliability silicon dioxide membrane and act as a heating element for the MOX based sensing material. The micro-hotplate can be used to heat the MOX material to up to 400°C and its electrical resistance can be monitored to detect the target gas. Through enabling fast heater cycling times, temperature modulation techniques can be used to reduce the device power consumption and implement advanced gas sensing methods.

Advanced algorithms support the MOX gas sensors family, for maximum sensitivity, selectivity, drift compensation, and for self-calibration; enabling easy and timely integration into a wide range of products and applications.

Product Overview

CCS801 is an ultra-low power MOX multi-gas sensor for monitoring indoor air quality including Carbon Monoxide (CO) and a wide range of Volatile Organic Compounds (VOCs).

The sensitivity of CCS801 to a target gas is optimised by adapting the supply voltage (V_H) of the integrated micro-heater, and the gas concentration can be correlated to the change in resistance of the MOX sensing layer (R_s).

V_H can be set using a low-dropout (LDO) regulator or operated in pulsed PWM mode to reduce power consumption. The sensor resistance (R_s) is determined using a series load resistor (R_L), a reference voltage (V_{REF}), and an output voltage (V_{OUT}) read by an Analogue-to-Digital Converter (ADC).

Miniaturisation

The CCS801 multi-gas sensor is supported in a compact 2 mm x 3 mm Surface Mount Device (SMD) package as standard. Other package options including TO are available on request. The inherent design of this sensor enables ultra-low power consumption for battery operated portable handheld devices.

Key Benefits

- Ultra-low power consumption for battery operated devices
- High sensitivity and fast heating times
- Compact 2 mm x 3 mm SMD package for small form factor designs

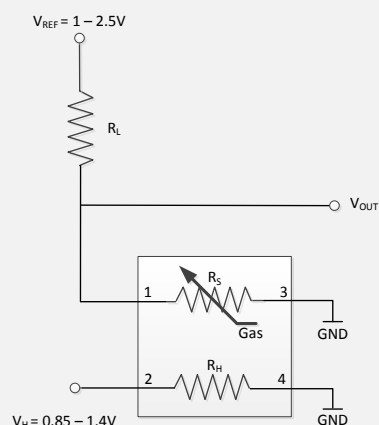

Recommended Sensor Configuration

Applications

- Indoor air quality monitoring for smartphones and tablets
- Alcohol breathalyser
- Gas leakage detection

